

**CONSTRUCTION OF A MICROCONTROLLER BASED SECURITY  
DOOR USING SMART CARD**

**BY**

**EGBUDIWE EZEKWESIRIM .N**

**EE/2007/181**

**DEPARTMENT OF ELECTRICAL /ELECTRONIC ENGINEERING**

**FACULTY OF ENGINEERING**

**CARITAS UNIVERSITY, AMORJI-NIKE ENUGU**

**AUGUST 2012**

**CONSTRUCTION OF A MICROCONTROLLER BASED SECURITY  
DOOR USING SMART**

**BY**

**EGBUDIWE EZEKWESIRM .N**

**EE/2007/181**

**BEING A PROJECT SUBMITTED IN PARTIAL FULFILMENT OF THE  
REQUIREMENT FOR THE AWARD OF BACHELOR OF ENGINEERING  
(B.ENG) DEGREE IN ELECTRICAL/ELECTRONIC ENGINEERING**

**CARITAS UNIVERSITY, AMORJI-NIKE ENUGU**

**AUGUST 2012**

## CERTIFICATION

This is to certify that this work was carried out by, **EGBUDIWE .N.**

**EZEKWESIRM** of the department of Electrical/Electronic Engineering, Caritas

University Amorji-nike, Enugu.

\_\_\_\_\_

**Date:** \_\_\_\_\_

**Engr. E.C. Aneke**

*Project Supervisor*

\_\_\_\_\_

**Date:** \_\_\_\_\_

**Engr. C.O Ejimofor**

*Head of Department*

\_\_\_\_\_

**Date:** \_\_\_\_\_

*External supervisor*

## **DEDICATION**

The work is dedicated to the almighty God who with all his conglomerate efforts made my dream come true.

## **ACKNOWLEDGEMENT**

My Profound gratitude goes to God Almighty who gave me good health and the strength throughout the period of this project. To my parents and siblings, I say a very big thank you for your financial and moral support during and after the completion of this project.

My special thanks also go to my supervisor Engr. E.C Aneke and together with all other lecturers of the department.

## **ABSTRACT**

This project shows the construction of a microcontroller based security door using smart card. It is aimed towards programming the microcontroller to control the hardware in sliding door. The system consists of a microcontroller 89S52 which sends a signal to the multiplexers on insertion of the smart card in the card slot. The multiplexers consist of ICS which prompts for a display of the identity of the card user in the liquid crystal display (LCD). The LCD displays the status of the card. On validation of the card, the LCD displays a welcome note to the user and prompts for a pin code. The pin code is being keyed in from the key pad. If confirmed by the program written into the microcontroller access will be granted, otherwise no access, giving the user two more chances to insert the correct smartcard or pin code to it, before final denial of access and alarm. When access is granted, the card sends a 5volt signal to the microcontroller which triggers relay, resulting in the opening of the door.

## TABLE OF CONTENTS

Title Page	-	-	-	-	-	-	-	i
Approval Page	-	-	-	-	-	-	-	ii
Dedication	-	-	-	-	-	-	-	iii
Acknowledgement	-	-	-	-	-	-	-	iv
Abstract	-	-	-	-	-	-	-	v
Table of contents	-	-	-	-	-	-	-	vi
List of Tables-	-	-	-	-	-	-	-	xi
List of Figures	-	-	-	-	-	-	-	xii
Glossary of Symbols / Abbreviations	-	-	-	-	-	-	-	xiii

### CHAPTER ONE

1.0	Introduction	-	-	-	-	-	-	1
1.1	Areas of application	-	-	-	-	-	-	4
1.2	Aims and Objectives	-	-	-	-	-	-	5
1.3	Project Scope	-	-	-	-	-	-	5

### CHAPTER TWO

2.0	Literature review	-	-	-	-	-	6
2.1	Mechanism of Security of access system	-	-	-	-	-	7
2.1.2	Types of security access system	-	-	-	-	-	8
2.1.3	Sound activated lock system	-	-	-	-	-	8
2.1.4	Shadow detector access system	-	-	-	-	-	8
2.1.5	Pressure and pad sensitive security system	-	-	-	-	-	9
2.1.6	Smartcard access system	-	-	-	-	-	9
2.1.7	History	-	-	-	-	-	10
2.2	The components used	-	-	-	-	-	12
2.2.1	The microcontroller	-	-	-	-	-	12
2.2.2	Elements of a microcontroller	-	-	-	-	-	12
2.2.2.1	The CPU	-	-	-	-	-	13
2.2.2.2	Ram	-	-	-	-	-	13
2.2.2.3	Eprom	-	-	-	-	-	14
2.2.2.4	Input / Output	-	-	-	-	-	14
2.2.3	Relay	-	-	-	-	-	14



2.2.4 Liquid crystal display	-	-	-	-	-	16
2.2.5 Key pad	-	-	-	-	-	16
2.2.6 Active components	-	-	-	-	-	17
2.2.6.1 Transistor	--	-	-	-	-	17
2.2.6.2 Diodes	-	-	-	-	-	18
2.3.0 Passive component	-	-	-	-	-	19
2.3.1 Resistor	-	-	-	-	-	19
2.3.2 Capacitor	-	-	-	-	-	22
2.3.3 Transformer	-	-	-	-	-	23
2.4 Micro switches	-	-	--	-	-	24

## CHAPTER THREE

### 3.0 Design analysis of the electric circuit and

Mechanical unit	-	-	-	-	-	25
-----------------	---	---	---	---	---	----

3.1	Hardware design	-	-	-	-	-	25
3.2	Keypad select module	-	-	-	-	-	27
3.3	Sliding door unit	-	-	-	-	-	28
3.4	Alarm signal unit	-	-	-	-	-	31
3.5	Display unit	-	-	-	-	-	32
3.5.1	Display unit calculation	-	-	-	-	-	33
3.6	89S52 microcontroller	-	-	-	-	-	34
3.6.1	Powering the microcontroller	-	-	-	-	-	37
3.6.2	Crystal oscillator unit	-	-	-	-	-	39
3.7	smartcard unit	-	-	-	-	-	39
3.8	Power supply unit	-	-	-	-	-	40
3.8.1	Step down	-	-	-	-	-	41
3.8.2	Rectification	-	-	-	-	-	41
	Filtering	-	-	-	-	-	43
3.9	synchronous 12v DC motor	-	-	-	-	-	44
3.10	mechanical unit	-	-	-	-	-	45
3.10.1	Fabrication of component parts	-	-	-	-	-	45
3.10.2	Mechanism casing	-	-	-	-	-	46
3.10.3	Door post	-	-	-	-	-	46
3.10.4	The door	-	-	-	-	-	46

3.11	software development	-	-	-	-	47
3.11.1	text editor	-	-	-	-	47
3.11.2	Translator	-	-	-	-	47
3.11.3	Link / locator	-	-	-	-	48
3.11.4	Loader	-	-	-	-	48
3.11.5	Testing	-	-	-	-	48
3.11.6	Debugging	-	-	-	-	48
3.12	Development process	-	-	-	-	49
3.13	Program entry and editing			-	-	49
3.14	Assembly and linking	-	-	-	-	49
3.15	Hexadecimal conversion	-	-	-	-	50
3.16	Circuit design diagram	-	-	-	-	51

## CHAPTER FOUR

### 4.0 Material selection, assembly process,

	Cost analysis, test and result.	-	-	-	52
--	---------------------------------	---	---	---	----

4.1	Material selection	-	-	-	52
-----	--------------------	---	---	---	----

4.2	Assembly process	-	-	-	53
-----	------------------	---	---	---	----

4.3	Cost analysis	-	-	-	53
-----	---------------	---	---	---	----

4.4	Test and Result	-	-	-	55
-----	-----------------	---	---	---	----

## CHAPTER FIVE

### 5.0 Discussion of results, Conclusion and Recommendation

5.1 Discussion of results - - - 56

5.2 Conclusion - - - 56

5.3 Recommendation - - - 57

References

### LIST OF TABLES

Table 2.1: Resistor color coding - - - 21

Table 4.1: cost analysis - - - 54

## LIST OF FIGURES

Fig 2.1: The CPU of a microcontroller	-	-	13
Fig 2.2: Diagram of a Relay	-	-	15
Fig 2.3: Keypad	-	-	16
Fig 2.4: Diagram of NPN and PNP Transistor	-	-	17
Fig 2.5: Diagram of Resistor color coding	-	-	20
Fig 2.6: Diagram of a Transformer	-	-	23
Fig 3.1: Block diagram of the project	-	-	26
Fig 3.2(a): Diagram of Keypad increment button	-	-	27
Fig 3.2(b): Diagram of Keypad decrement button	-	-	27
Fig 3.2(c): Diagram of Keypad Adjust button	-	-	28
Fig 3.2 (d): Diagram of Keypad Reset button	-	-	28
Fig 3.3: Diagram of Relay Connection to the door	-	-	29
Fig 3.4: Diagram of a Transistor	-	-	31
Fig 3.5: Diagram of the alarm signal unit	-	-	31

Fig 3.6: Diagram of the microcontroller	-	-	36
Fig 3.7: Powering the microcontroller	-	-	38
Fig 3.8: Diagram of crystal oscillator unit	-	-	39
Fig 3.9: The smart card unit	-	-	39
Fig 3.10: Diagram of the power supply	-	-	40
Fig 3.11: Rectifier bridge	-	-	42
Fig 3.12(i): Single capacitor filter	-	-	43
Fig 3.12(ii): Inductor filter	-	-	43
Fig 3.12(iii): Pie filter	-	-	44
Fig: 3.13: Circuit Design Diagram	-	-	51

## **GLOSSARY OF SYMBOLS / ABBREVIATIONS**

I Current

V Voltage

R Resistance

F Frequency

C Capacitance

W Power

IC Integrated circuit

LED Light Emitting Diode

AC Alternating current

DC Direct current

CPU Central Processing Unit

Ohms

NPN Negative – Positive – Negative

PNP Positive – Negative – Positive

1/0 Input/output

Vcc +5v = 1

GND Ground (0v)

EA Enable

ALE Address Latch enable

PSEN Program Latch enable



# CHAPTER ONE

## 1.0 INTRODUCTION

Creation of secured access path to offices, homes, hotels, industries etc. has been a successful discovery of man. As a result of this, it has been possible to create door/gates that are well secured using smart card.

Individuals are becoming more aware of the dangers/ risk associated with relying on keys or padlocks to provide security to unauthorized areas of their apartments. Fraudsters/criminals can forge keys or make master keys that will be used to break into such rooms or offices. To eliminate this insecure and old fashioned method, the use of password in doors/gates mechanism evolved. The development of single secret authentication such as password is an effective security control.

A long pass-word of more than ten characters that consists of random letters, numbers and special character can be very difficult to crack. Unfortunately, users cannot always remember the sort of pass-word, partly due to fundamental human limitations.

However, most security guidance recommends at least eight character random password. Because most users cannot commit eight character random password to memory and many attempt to write it down on a piece of paper which can be misplaced or seen by another person, while some users tend to choose easy to

remember passwords such as '123' or other easily guessed characters. Due to this shortcoming of a single secret authentication, creation of two factor authentication evolved.

Two-factor authentication i.e. System that uses card and pin code for authentication overcame the issues of single secret authentication by the requirement of a second secret. Two-factor authentication uses a combination of the following items;

- Something that the user has, such as hardware token or a smartcard.
- Something the user knows, such as personal identification number (pin).

Smartcard and their associated pins are becoming increasingly popular, reliable and cost effective. Two-factor authentication with the right control in place, the user must have the smartcard and know the pin code to gain access to the required apartment. The smartcard requirement significantly reduces the likelihood of unauthorized access to an organization's outfit.

Hence to reduce or eliminate the access of unauthorized personnel into unauthorized areas, an automated door/access path is to be constructed. This involves controlling the doors/gates by an artificial means (artificial intelligence). It involves the application of automated system that is incorporated into these doors/gates for efficient and optimum performance. Taking the advantage of the

microcontroller as one of the fastest processing and intelligent instrument, was incorporated into the system and interfaced with smartcard in order to achieve accuracy in processing.

This project was constructed using microcontroller for better creativity and beauty in design. The microcontroller (programmable) has series of instruction fed into it, this help it to accomplish most intelligent task like the human brain. These include detection of card, identification of password, displaying “access granted”, “access denied” and opening and closing of door/gate with the aid of the smart card. An electromagnetic relay controls the opening and closing of the door/gate which is moved to and fro by a synchronous motor (DC).

The microcontroller based security door using smart card is designed using the 89S52 microcontroller with appropriate software package. The project is segmented into different module which includes; the mechanical, electrical/electronic and programmable (computerized) part as listed below;

1. The microcontroller module
2. The keypad module
3. Electromagnetic relay
4. The display unit (module)

5. The Smart card module
6. The alarm signal module
7. The sliding door/gate
8. Electric motor
9. The Power Supply Module etc.

**The microcontroller:** The microcontroller does most of the addressing and instruction execution through its data, address and control busses.

**The Keypad:** The keypad is used for selection i.e. As an input device to issue instruction to the control processing unit (CPU) of the processor.

**The smart card and its associated pin:** provide the security system.

**The Display Module:** the display module shows the output of events that are taking place.

**The Electromagnetic Relay:** The help of the relay is utilized by the CPU to switch the motor ON which moves or turns causing the gate/door to slide to the defined direction.

**The Alarm Unit:** The alarm unit produces an alarm signal when a wrong password or pin code is entered more than three times.

**The power supply Unit:** The power supply unit supplies a voltage for optimum operation of the circuit.

In all, this project demonstrates the integral function of what is obtainable in real system.

## **1.1 AREAS OF APPLICATION**

This project is applicable in areas where unauthorized personnel are restricted from access as can be seen in

- Offices
- Hotels
- Residential quarters
- Banks Security System
- Credit or ATM cards
- Authorization card for pay television
- Sims for mobile phones

## **1.2 AIMS AND OBJECTIVES**

The major aim of this project is to construct a system that uses two-factor authentication (smart card and their associated pins) to provide security control to

reduce the threat of authorized access to some restricted areas. It also aims at bridging the technological gap between developing and developed countries of the world.

### **1.3 PROJECT SCOPE**

The construction of security door using smart card is based on discrete components like resistors, transformers, Liquid crystal display, transistors, relays, microcontroller, D.C motor, diodes, bridge rectifier, bolt and nuts, aluminum etc. This project design can be mounted on hotels door, office door etc with the incorporation of big dc motor and thyristor that will be able to drive specially constructed sliding gate/door when activated.

## CHAPTER TWO

### 2.0 LITERATURE REVIEW

Security access system is an important aspect of any system. Security access control is the act of ensuring that an authenticated user has access only when they are authorized to and nobody else. Security consciousness is highly needed where our environment and health is concerned.

There are two stages that are associated with security access control system, they are;

- Authentication
- Authorization

Authentication is the act of determining the identity of a user and the host that they are using. The goal of authentication is to first verify that the user, either a person or system, who is attempting to interact with your system is allowed to do so. The second goal of authentication is to gather information regarding the way that the user is accessing the system.

There are several other methods by which a system identifies a user some of the methods are viz;

**USER ID AND PASSWORD:** This is most common and typically the simplest approach to identifying someone because it is fully software based.

**PHYSICAL SECURITY DEVICES:** A physical device such as “speed pass” key chains by gas station is used to identify a person. Sometimes a password or personal identification number (pin) is also required to ensure that it is the right person.

**BIOMETRIC IDENTIFICATION:** Biometrics is the science of identifying someone from physical characteristics. This includes technologies such as voice verification, a retinal scan, palm identification and thumbprint.

Authorization is the act of determining the level of access that an authorized user has as to behavior and data.

## **2.1 MECHANISM OF SECURITY ACCESS SYSTEM**

Security access system runs on automated doors likewise on systems, which makes do with a smartcard device. When the smart card is inserted into it, it prompts the host for identification of card, if confirmed access will be granted, if not access will be denied. Before it denies access completely to that smartcard and pin code, the alarm gets activated when access is generated. The smartcard sends a voltage signal of 5volts which triggers the relay causing it to activate the dc motor. The



motor moves the movable part of the door to allow a person to pass through which it closes back at the removal of the smartcard.

### **2.1.2 TYPES OF SECURITY ACCESS SYSTEM**

There are different types of electric security devices, they are; switch activated lock system, sound activated system, shadow access lock system, light detector security system, pressure pad, sensitive security system and smartcard security access system etc. these systems are designed to serve different purpose as their names implies, their operation are related because some of them give access while some deny access.

### **2.1.3 SOUND ACTIVATED LOCK SYSTEM**

The principle behind the sound activated lock system is that, it uses sound. The system locks permanently when there is a noise in the environment. This system uses sequential IC's like 555 timer which is made to operate with high frequencies and microphones will trigger alarm if there is a change in its frequency. These systems are ideal in bank vaults.

#### **2.1.4 SHADOW DETECTOR ACCESS SYSTEM**

Another security access system is the shadow detector access system. This is mainly designed to be used at doors and places that need to be secured, the system works with alarm, but this device is highly inefficient because at the change in the intensity of light in bad weather and its function is restricted to only day hours.

#### **2.1.5 PRESSURE AND SENSITIVE SECURITY SYSTEM**

Pad with sensitive layers are hidden under the floor, when the system is activated alarm is triggered as pressure is applied on the pads. These pads are made of slightly suspended switch which closes the circuit and triggers alarm only when pressure is applied on it.

#### **2.1.6 SMARTCARD ACCESS SYSTEM**

The card access control system secures an area using an electronic door locking mechanism that requires a card reader and valid card to access the area. Only persons who are permitted to access the area and who have been issued valid cards may gain entry. And the card is embedded with either a microprocessor or a memory chip, only a memory chip with non-programmable logic. The

microprocessor can add, delete and manipulate information on the card, while a memory chip card (for example pre-paid phone cards) can only undertake a pre-defined operation. Card access control may be installed for offices, labs or buildings.

### **2.1.7 HISTORY OF SMARTCARDS**

Smart cards have evolved into highly sophisticated and electronic device that have multiple functions and are used in various areas of life. The first card was highly advanced but very expensive to manufacture. The miniaturization of electronic components in 1978 made it possible to mass-produce smartcard, it can be found on every continent throughout the world.

The dates below show the historical milestone in the development of smartcard technology;

In 1970 Dr. Kunitaka Arimura of Japan fields the first and only patent on the smart card concept. In 1974 Roland Moreno of France fields the original patent for the IC card product<sup>1</sup>.

---

In 1977 three commercial manufacturers, Bill CP 81, SGS Thomson, and Schlumberger began development of the IC card product.

In 1979 Motorola developed the first secure single chip microcontroller for use in France banking.

In 1984 field trials of ATM bank card with chips were successfully conducted.

In 1986 march to be precise, 14, 000 cards equipped with the Bill CP8 were distributed to clients of Bank of Virginia and the Maryland National Bank. Also 50000 casino cards were distributed to clients to the National Palm Beach Bank and the Mill Bank<sup>2</sup>.

In 1991 first electronic benefits transfer smartcard project launched for the special supplement nutrition program for women, infants and children (WIC).

In 1994 Europlay, MasterCard and visa (EMV) published joint specification for global microchip-based bankcards (smart card). Germany began issuance of 80 million serial memory chip cards as citizen health cards.

In 1995 over 3 million digital mobile phone subscribers worldwide began initiating and building calls with smart cards. First of 40000 multi-functional, multi-

---

technology MARC card with chips where 1.5million VISA cash card valve chips were issued at the Atlanta Olympics.

Smartcard are continuously introduced into different areas of life around the globe. According to Walters, 1992 smart card is a standard-sized plastic card that contains an integrated circuit of chips which give that card the ability to store and or process data. The smart card is characterized by its chip, with its ability to store much more data than is held on a magnetic stripe, all within an extremely secure environment.

Smartcard can be used for a wide variety of general purpose, e.g authentication, data storage and data processing. There are many specific applications of the generic functions with particular industry sector such as security access control.

## **2.2 THE COMPONENTS USED**

To achieve this design various individual components will be put together among which are described below;

### **2.2.1 THE MICROCONTROLLER**

A microcontroller is a one-chip or basically a device which integrates a number of computers of a microprocessor system onto a single microchip. It is highly integrated chip which includes chip all (at least most) of the parts needed for a

controller. Because the microcontroller is designed to control, they have compact components designed specially for their task. The system is small, low cost and consists of instruction, directly accessing I/O and fast and efficient interrupt control.

## **2.2.2 ELEMENTS OF A MICROCONTROLLER**

The following are the various elements of the microcontroller;

- The CPU core
- Ram
- EPROM
- Serial input / output port
- Timers
- Interrupt

### **2.2.2.1 THE CPU**

This is the heart of the microcontroller and it's responsible for the execution of program instructions. The type of instruction executed by the CPU includes arithmetic, logic, data and program branching instructions

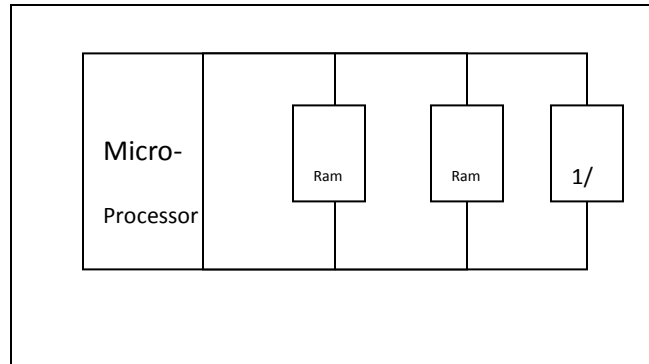

Fig. 2.1: The CPU

#### 2.2.2.2 RAM

All microcontroller system needs memory. Memory according to J. Bigelow is basically an array of individual storage element organized into row and columns. Each row is regarded as address while the columns represent the data bits. These memories can be both read from and written to. Ram is used to store dynamic data. This type of memory is very volatile and loses data when there is power supply failure on the system.

### **2.2.2.3 EPROM**

This is like ROM but can be programmed by the user. Its contents can be changed through exposure to ultra-violet radiation for a short period of time, hence the name EPROM (Erasable Programmable Read only Memory). Some version of EPROM is Eeprom (Electrical Erasable Programmable Read Only memory). Its content can be erased by microprocessor. The memory of these chips is to hold the program code of the processor.

### **2.2.2.4 INPUT/OUTPUT PORT**

A serial I/O port allows data to flow between the microcontroller and other devices

### **2.2.3 RELAY**

A relay is an electromagnetically operated switch that functions with the principle of electromagnetic induction. It is made up of a coil armature circuit which closes contact by induction upon receiving a specified voltage input from the source. The relay is described by the number of lines (poles) that are controlled and the number of contact (throw) each pole can make.



When the switch in the relay circuit is closed, the electromagnet is energized while the armature is attached to a fixed contact point. But when the switch is open the relay coil is de-energized.

A general purpose power relay is rated in terms of;

i. The operating voltage rating of the relay coil and it is to be operated with either an Ac or Dc voltage.

ii. The resistance of its coil

iii. The current rating of its contacts.

The relay can be illustrated diagrammatically as shown in fig. 2.2 below

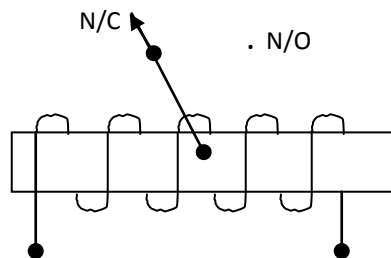

Fig. 2.2: Diagram of a relay

## 2.2.4 LIQUID CRYSTAL DISPLAY

This type of display comes in variety of colors, sizes and packaging style. It's mode of fabrication is based on the application of electricity to cells made of liquid crystal. The liquid crystal display gets its name from the fact that it has a dual nature or characteristics of both liquid and solid. However, when electricity is applied to one of the segments of liquid crystals (segments are switched on and off to form the images you see on the screen). The crystals line up in such a way that they make the light turn through 90 degree in between the two panels and become visible on the other side.

## 2.2.5 KEYPAD

The keypad is an input device designed to issue instruction to a microcontroller. It consists of increment, decrement, select, enter and reset button. Each key upon being depressed transmit its instruction to the central processing unit of the microcontroller. The keypad is constructed as shown below.

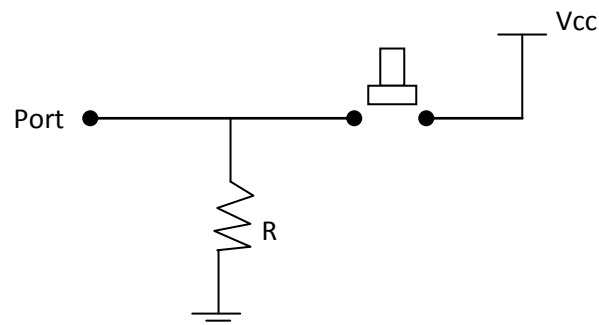

Fig. 2.3 Keypad

## 2.2.6 ACTIVE COMPONENTS

### 2.2.6.1 TRANSISTOR

Transistors have become the most important single building block in electronics. It is the modern miniature semiconductor equivalent of the vacuum tube and was invented in 1947 by Bardeen, Shockley and Brattain at USA. Transistors are packaged as separate and discrete-component. There are two basic types of transistor, the bipolar junction transistor (BJT) and Field Effect transistor (FET)

From the project in study, the type of transistor used belongs to the class of bipolar junction transistor. Bipolar transistor consists of three pieces of semiconductor material sandwiched together known as base, collector and emitter. It is known as a three-terminal device. The Bipolar junction transistor (BJT) can be sub-grouped into

a) NPN

b) PNP



Fig 2.4 (a) NPN and (b) PNP

In NPN transistor, when current flows into the base terminal, much current are driven between the collector and the emitter. They are considered current gain of the transistor and it's typically 100. The type of transistor used is the BC547 and T1P4 that amplify electrical signal for switching the relay device. Its maximum current IC is 500mA.

### **2.2.6.2 DIODES**

A diode is two terminal active, non-linear device used in containing voltage and current in a circuit. It allows current to flow in one direction, the device is said to be forward current biased when the voltage applied the diode is positive related to the cathode. The direction of forward biased the effective resistance across the diode is very low. But when reversed biased would be a perfect conductor for forward current and a perfect insulator for reverse current.

Diode can be used as a rectifier. It can convert alternating current to direct current. They can be arranged in a four-terminal semicircular way to form a bridge rectifier. It has two source terminals, a positive terminal and a negative terminal alternating voltage is being connected to the source inputs. Rectified outputs come out through the other two terminals.

## 2.3.0 PASSIVE COMPONENTS

### 2.3.1 RESISTOR

A resistor is a device designed to have a specific amount of resistance to the passage of current. Resistor is used in circuit to limit current flow, provide a voltage drop or other related functions like limiting current passing through some components like the liquid crystal display (LCD), transistor and diodes. The value of each resistor determines the current flowing through it and the value can be determined by the color band on the resistor. The resistance of a resistor is a fundamental property of such resistor as shown.

$$R = V/I$$

Where      R = Resistance of the resistor

              V = voltage of the resistor

              I = Current of the resistor

Resistor can be connected in series or parallel depending on the need. Its unit is measured in Ohms ( $\Omega$ )

### RESISTOR IN SERIES

The resistors are joined end-on-end as shown below. It can be proved that the equivalent resistance or total resistance between points A and D is equal to the sum of the three individual resistances.

$$R = R_1 + R_2 + R_3 + \dots$$

### RESISTOR IN PARALLEL

They are joined in parallel, in this case the potential difference across one resistance is the same and the current in each resistor is different and is given by ohm's law

$$I/R = I/R_1 + I/R_2 + I/R_3 + \dots$$

Below is the color band of a resistor

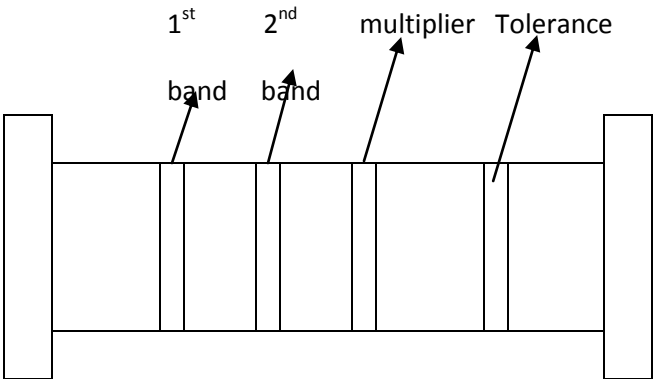

Fig 2.5: Resistor color coding

Color	1 <sup>st</sup> band	2 <sup>nd</sup> band	Multiplier	Tolerance
Black	0	0	X1	
Brown	1	1	X10	±1
Red	2	2	X100	±2
Orange	3	3	X1k	
Yellow	4	4	X10k	
Green	5	5	X100k	±0.5
Blue	6	6	X1m	±0.25
Violet	7	7	X10m	±0.1
Gray	8	8		±0.05
White	9	9		
Gold			X0.1	±5
Silver			X0.01	±10

Table 2.1: Resistor color coding table

### 2.3.2 CAPACITOR

A capacitor essentially consists of two conducting surface separated by a layer of an insulating medium called dielectric. The conducting surface may be in the form of either circular (or rectangular) plates or be of spherical or cylindrical shape. The purpose of a capacitor is to store electrical energy by electrostatic stress in the dielectric. Its plates are at different potential and it is referred to as capacitance of the capacitor. The unit of capacitance is farads (f), which may be defined as the capacitance of a capacitor between the plates of which there appears a potential difference of 1 volt when it is charged by 1 coulombs of electricity.

Charge (coulombs) = capacitance

Applied p.d (volts)          farads

Or symbol  $Q/v = C$

Therefore  $Q = CV$  coulombs

Capacitors can be connected in parallel or in series. The resultant of capacitance of capacitors in parallel is the arithmetic sum of their respective capacitances.

$$C = C_1 + C_2 + C_3$$

While the reciprocal of the resultant capacitance of capacitors connected in series is the reciprocal of their respective capacitance.



$$1/C = 1/C_1 + 1/C_2 + 1/C_3$$

Factors that affect the value of a capacitor depend primarily on:

- Area of plates
- Separation distance between plates and
- The dielectric constant of the dielectric material between the plates.

### **2.3.3 TRANSFORMER**

A transformer is a static (or stationary) device by which electric power in one circuit is transformed into electric power of the same frequency in another circuit.

It can raise or lower the voltage in a circuit but with a corresponding decrease or increase in current. The physical basis of a transformer is mutual induction between two circuits linked by a common magnetic flux. In brief, a transformer is a device that;

- Transfer electric power from one circuit to another
- It does so without a change of frequency
- It accomplishes this by electromagnetic induction and where the two electric circuits are in mutual inductive influence of each other.

The diagram is as below:

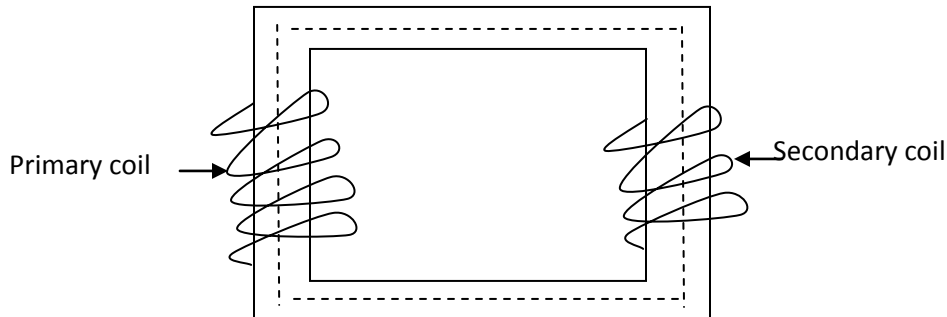
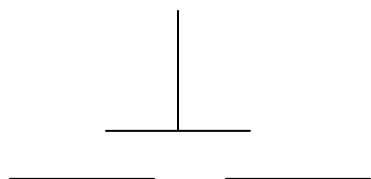

Fig 2.6: Transformer

## 2.4 MICROSWITCHES

A switch is used to join two connections. There are two types of switch namely: Bistable and monostable switch. Bistable switch is one that stay in either position e.g. electric light switch, which can stay on or off, while monostable is normally off. If someone presses the switch it comes on and if released, it switches off again. It is a type of switch that keeps a terminal open so that when pressed it introduces a bit and then returns to its normal state, which can be normally high or low. So it implies that the micro-switch is simply a push-pull switch. The symbol of the PUSH-FULL switch is as shown below:



## **CHAPTER THREE**

### **3.0 DESIGN ANALYSIS OF THE ELECTRIC CIRCUIT AND MECHANICAL UNIT**

This chapter covers extensively the major components that are used in the circuit design of the project including an indebt analysis of the various module and functions of the part that constitute the module and functions of the part that constitute the design. Design calculations, software development, hardware design and assembly language are all thoroughly treated.

#### **3.1 HARDWARE DESIGN**

The construction of security door using smart card is based on hardware and software. The hardware comprises of modules that are segmented on the Vero board as well as physical wiring which ensures optimum performance of the whole circuiting. The hardware design of the project consists of six essential modules which include keypad select module, sliding gate module, display module and power supply unit module.

The keypad select module as an input is used to issue instructions (entering of pin) to the microcontroller while the display unit displays either “enter pin, access denied, or access granted”. It shows the pin as it is being entered.

The sliding gate unit open and closes for human passage after being triggered by relays, while the power supply unit provide the appropriate dc voltage needed for the circuit operation. The smart card unit detects a card if it is configured to the system. If the card is configured to the system, it sends a signal to the microcontroller which now displays “enter pin”. The microcontroller is the heart of the entire circuiting. It gives instruction to the different modules. There is also the alarm signal which issues a signal in form of a sound when a wrong pin is entered in the system more than three times.

**BLOCK DIAGRAM**

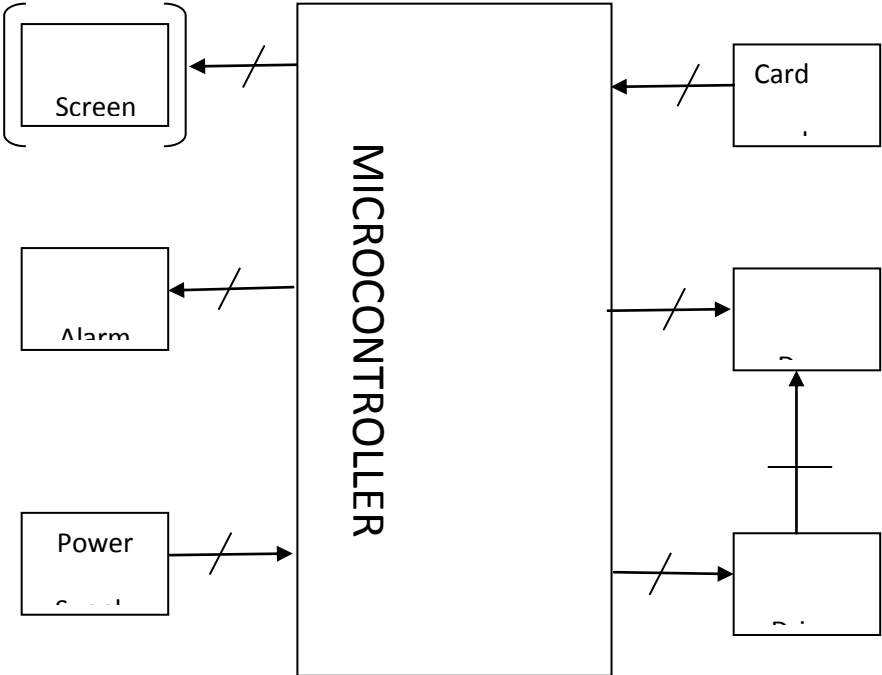

Fig 3.1

## KEYPAD SELECT MODULE

The keypad is an input device designed to issue instruction to the microcontroller. It consists of increment, decrement, adjust, enter and reset buttons. Each key upon being depressed transmit its instruction to the central processing unit of the microcontroller. The keypad is found at the output port of the microcontroller. In this project, the interface is at port 2 bit 0,1,2,3 (P2.0, P2.1, P2.2, P2.3) and Pin 9 as the reset (see fig 3.8). Each of the button are tied with a pull-up resistor (1k), grounded through the 1k resistor, and the other side is connected to Vcc as shown in the figure below.

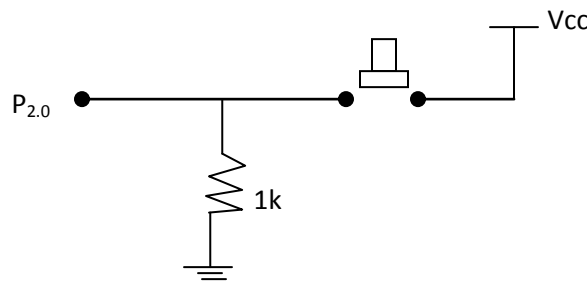

Fig 3.2 (a) Increment button

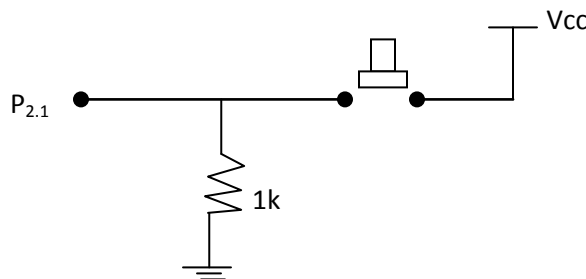

Fig 3.2 (b) Decrement button

Fig 3.2 (c) Adjust

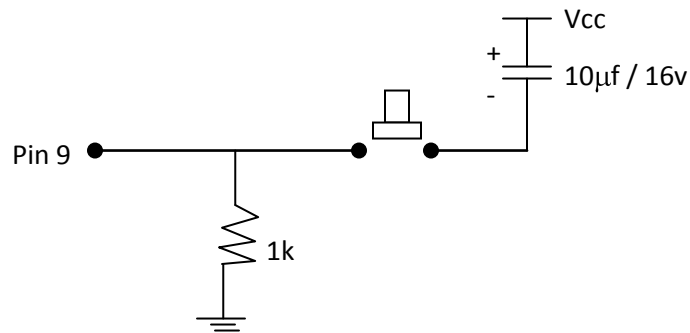
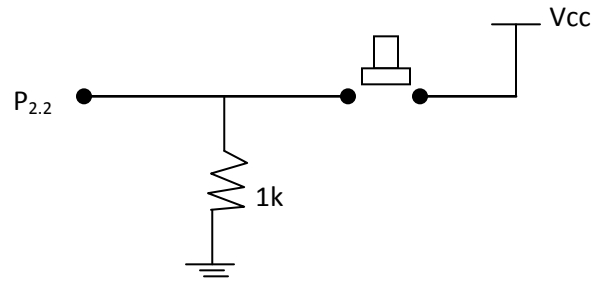

Fig 3.2 (d) Reset

As can be seen the keypad is connected as a normally low switch.

### 3.3 SLIDING DOOR UNIT

This unit consists of a dc motor and series of mechanism that drives the gate to open/close position. This occurs after the correct card and pin is detected. The process takes place after signal's receptions from the microcontroller through

which the relay triggers the door from a pulsating dc voltage. 12v dc input supply for relay switch is used. This is shown in the diagram below.

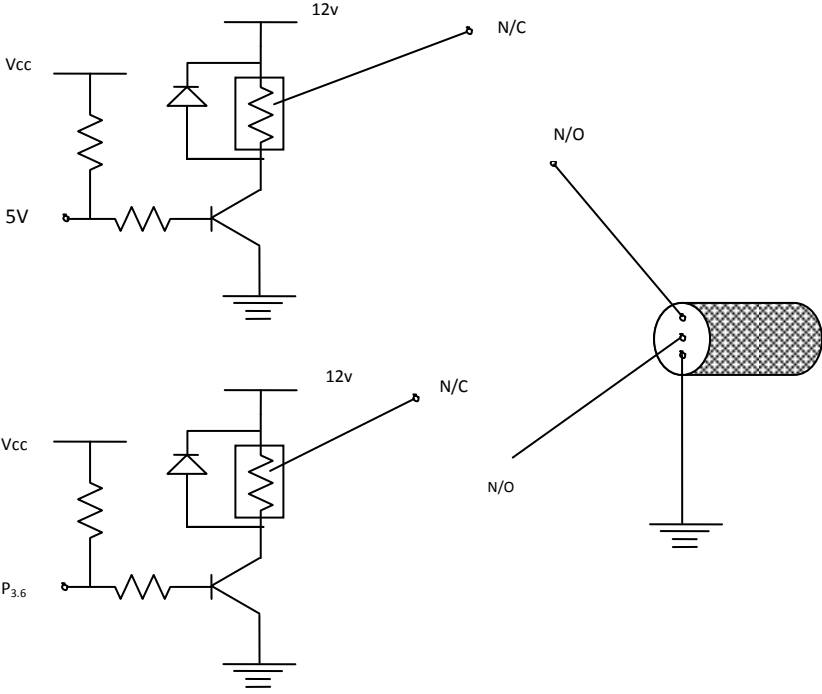

N/C = Normally close

N/O = Normally open

A critical look at the figure shows two relay with contact point showing when it is normally open (N/O) and normally close (N/C). It depicts different connection of two transistors (NPN) at different port to the microcontroller which aid in the movement of the gate in either direction. The first is a power transistor (NPN) found at port 3bit 6 (see fig 3.8). This operates when there is movement instruction (that is an active high pulse) from the microcontroller after a card and its associate pin is detected. A pull up is tied to Vcc at the base of the power transistor for optimum switching. The process energizes the relay (normally closed) and allows a maximum current flow from the collector to the emitter of the transistor. Placing an active low pulse at this port terminates the current. The transistor is chosen to handle a high current of 10mA which is IC max current and inductive effect of the dc motor.

The second transistor is found at port 3 bit 7 (P3.7) see fig 3.8. This operates at cut off region; the port is enabled when active low pulse is placed at the base of the transistor with a pull-up resistor inclusively. The relay contacts are de-energized (when normally open) which allows current to be discharged from the inductor of the relay to conduct emitter transistor. In order to avoid the stored current from damaging the transistor, a diode is connected to act as a feedback; the symbol of the transistor is given below



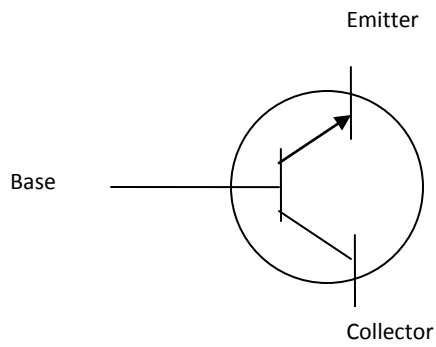

### 3.4 ALARM SIGNAL UNIT

This comprise of a speaker, resistor, capacitors, 555 timer and a transistor and it uses +5 dc

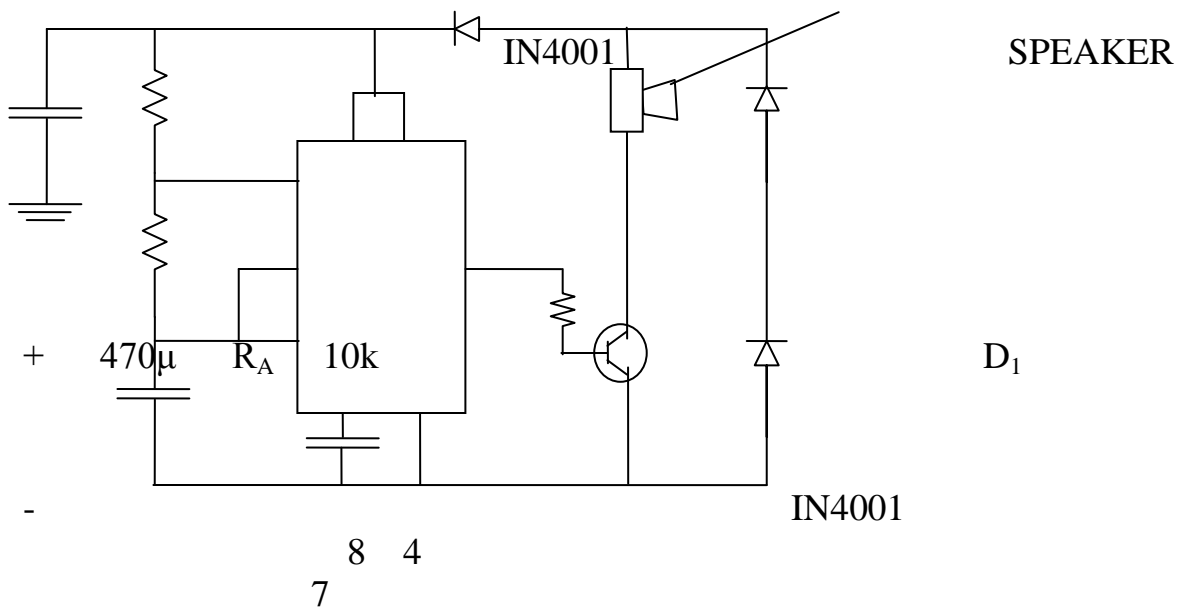

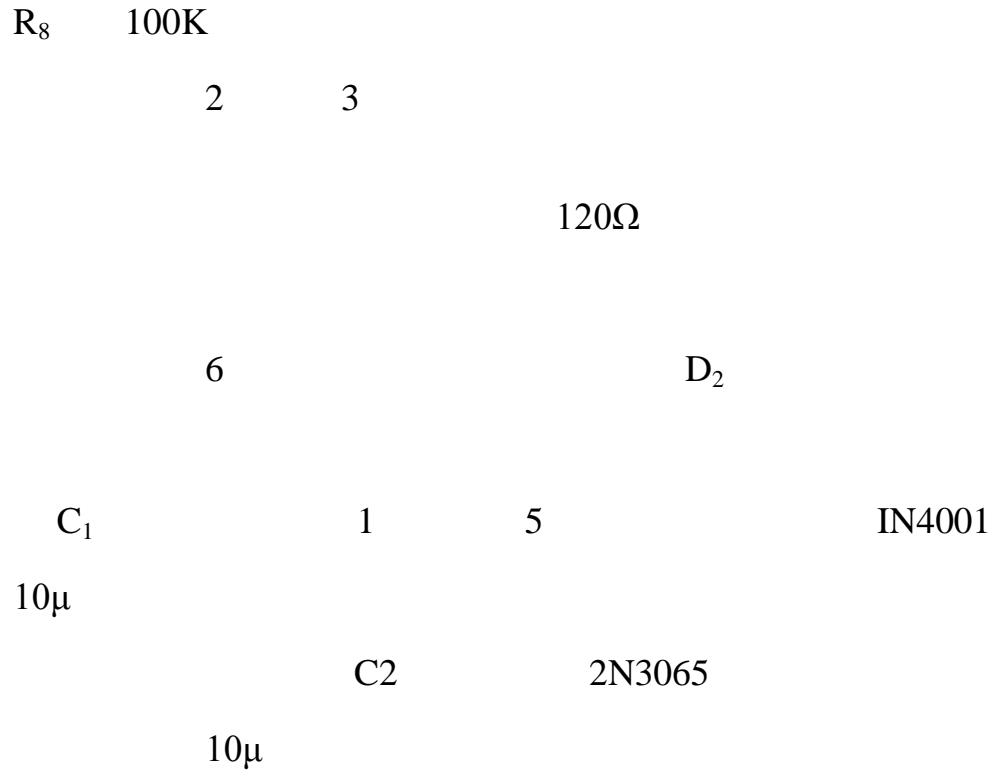

Fig 3.5 Alarm signal unit

As can be seen from the figure above, the frequency of the alarm signal can be obtained using

$$F = \frac{1.44}{(2R_B + R_A) C_1} (4^3)$$

---

(4)<sup>3</sup> N.N. linear IC (pocket Book) 555 Timer p 16.

R in ohms

C in farads

F in Hz

From the diagram above

$$R_A = 10k = 10000\Omega$$

$$R_B = 100k = 100000\Omega$$

$$C_1 = 10f = 10 \times 10^{-9}F$$

$$\therefore F = 1.44$$

$$(2 \times 100000 + 1000) \times 10 \times 10^{-9}$$

$$F = 685.71Hz$$

### **3.5 DISPLAY UNIT**

This unit is composed of resistor, transistor and LCD display. The pull-up resistor are tied to the output port (port 1) of the microcontroller and interfaced to the LCD through the transistors. The LCD display can be compare to the VDU (visual

display unit) in PCs. It does alpha-numeric display (both upper/lower case letter). The NPN transistor that is connected to it has its emitter being tied to Vcc through pull-up resistor (1k) as in the case of the relay, that is when a character is been displayed, a low voltage (usually 0 volts) to any turns it “ON”. In this display unit, the transistor acts as a switch. The aim of the pull-up resistor is to increase voltage when there is a pulse signal “1” in order to ensure a bright display. The connection is from the output port 1 bit (0-6) and output port 3 bit (0-5).

### **3.5.1 DISPLAY UNIT CALCULATION**

The display unit has two major calculation, they are:

- (1) Value of limiting resistor connected to the common of the seven segment display and
- (2) Value of the biasing resistor

To find the value of the limiting resistor connected to the common of the seven segment display, it should be noted that LCD takes a current of about 10.40mA which is very high and the microcontroller has a dc supply of 5volts from the power source So for a single display LCD will draw about 70-280mA and this takes about one third ( $\frac{1}{3}$ ) of the 5v supply. In order to allow about 4mA in each

LCD, the value of the limiting resistor is obtained using ohm's law which states that

$$V = IR$$

Where I = current (A)

V = voltage (v)

R = resistance (R)

Solving for the resistance of the resistor,

$$R = V/I \Rightarrow R = 5/4 \times 10^2$$

$$R = 125\Omega$$

Hence, there should not be less than 125Ω resistor connected to the resistor tied to the common of the liquid crystal display in this project design. 1k resistor was used as our preferred choice in this design

Therefore the limiting current is

$$I = \frac{5}{1000} = 5\text{mA}$$

$$1000$$

For the value of biasing resistor maximum base current of transistor is 5mA. The supply voltage is 5v dc. So applying ohm's law

$$V = IR \Rightarrow V = I_b R_b$$

$$R_b = \frac{V}{I_b} = \frac{5}{5} \times 10^3 = 1k\Omega$$

$$I_b = 5$$

So a resistor of value 1k is required to effectively bias the transistor.

## **89S52 MICROCONTROLLER**

The 89S52 is an 8-bit microcontroller originally developed by Intel in the late 1970's. It included an instruction set of 255 operation codes (opcodes), 32 input output line (i.e. port 1, port 2, port 3, and port 4), three user-controllable timers, an integrated and automatic serial port, and 256 bytes of chip RAM. The 89S52 was designed such that control of the microcontroller and all input/output between the microcontroller and external device is accomplished via special function Registers (SFR). The 89S52 microcontroller structure is below

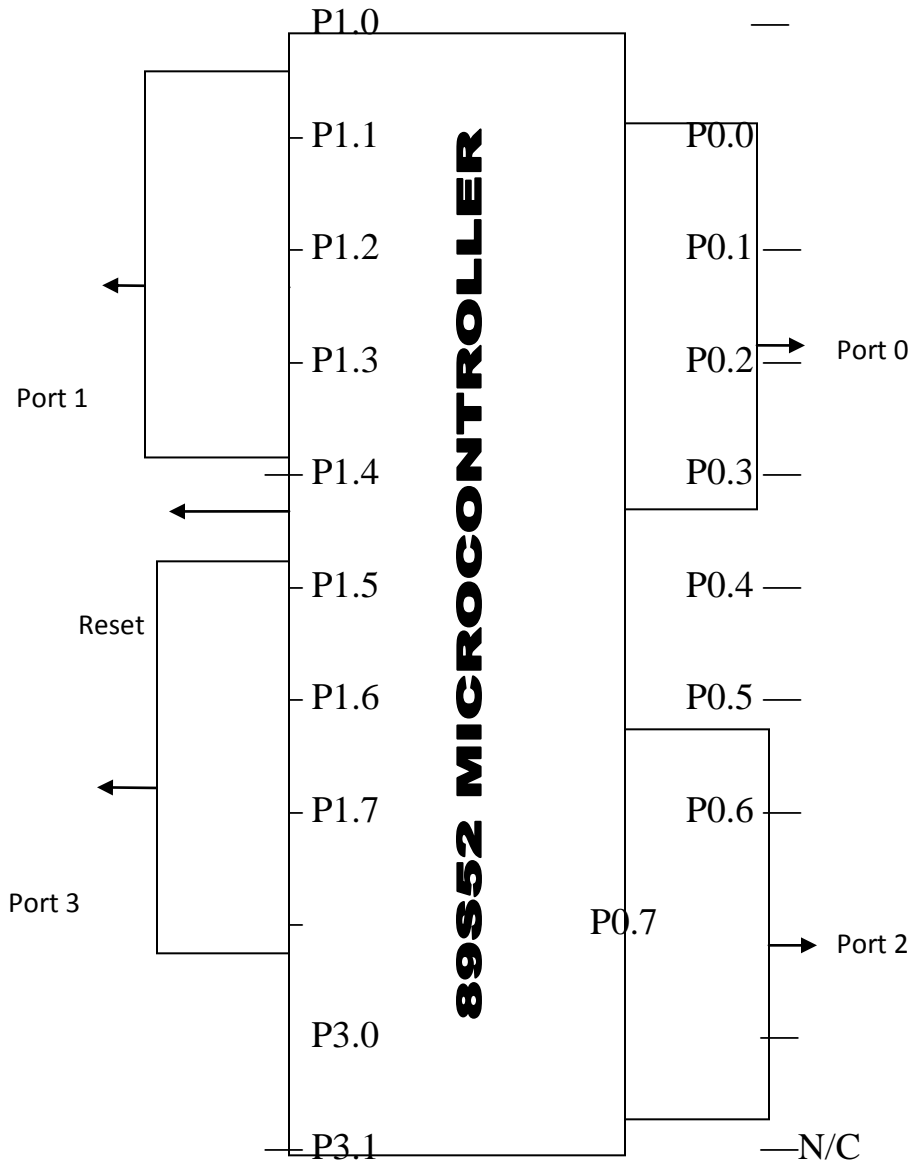

Fig 3.6 – the 89S52 Microcontroller

**PORT 1:** This is an input/output port. Each bit of this SFR corresponds to one of the pins on the microcontroller. For example, bit 0 of port 1 is P1.0, bit 7 is pin P1.7. Writing a value of 1 to a bit of this SFR will send a high level on the corresponding I/O pin whereas a value of 0 will bring it to a low level.

PORT 2: This is an input/output port. Each bit of this SFR responds to one of the pins on the microcontroller. For example bit 0 of port 2 is P2.0 bit 7 of port 1 is also P1.7. Writing a value of 1 to a bit of this SFR will send a high level on the corresponding I/O pin whereas a value of 0 will bring it to a low level.

PORT 3: This is an input/output port. Each bit of this SFR corresponds to one of the pins on the microcontroller. For example bit 0 of port 3 is P3.0, bit 7 is pin P3.7. Writing a value of 1 to a bit of this SFR will send a high level on the corresponding I/O pin whereas a value of 0 will bring it to a low level.

PORT 0: This is an input/output port. Each bit of this SFR corresponds to one of the pins on the microcontroller. For example bit 0 of port 0 is P0.0, bit 7 is pin P0.7. Writing a value of 1 to a bit of this SFR will send a high level on the corresponding I/O pin whereas a value of 0 will bring it to low level.

### **3.6.1 POWERING THE MICROCONTROLLER**

The power of microcontroller, pin 20 is connected to ground while pin 31 is connected to pin 40 and tied to Vcc. This is shown in details in the figure below



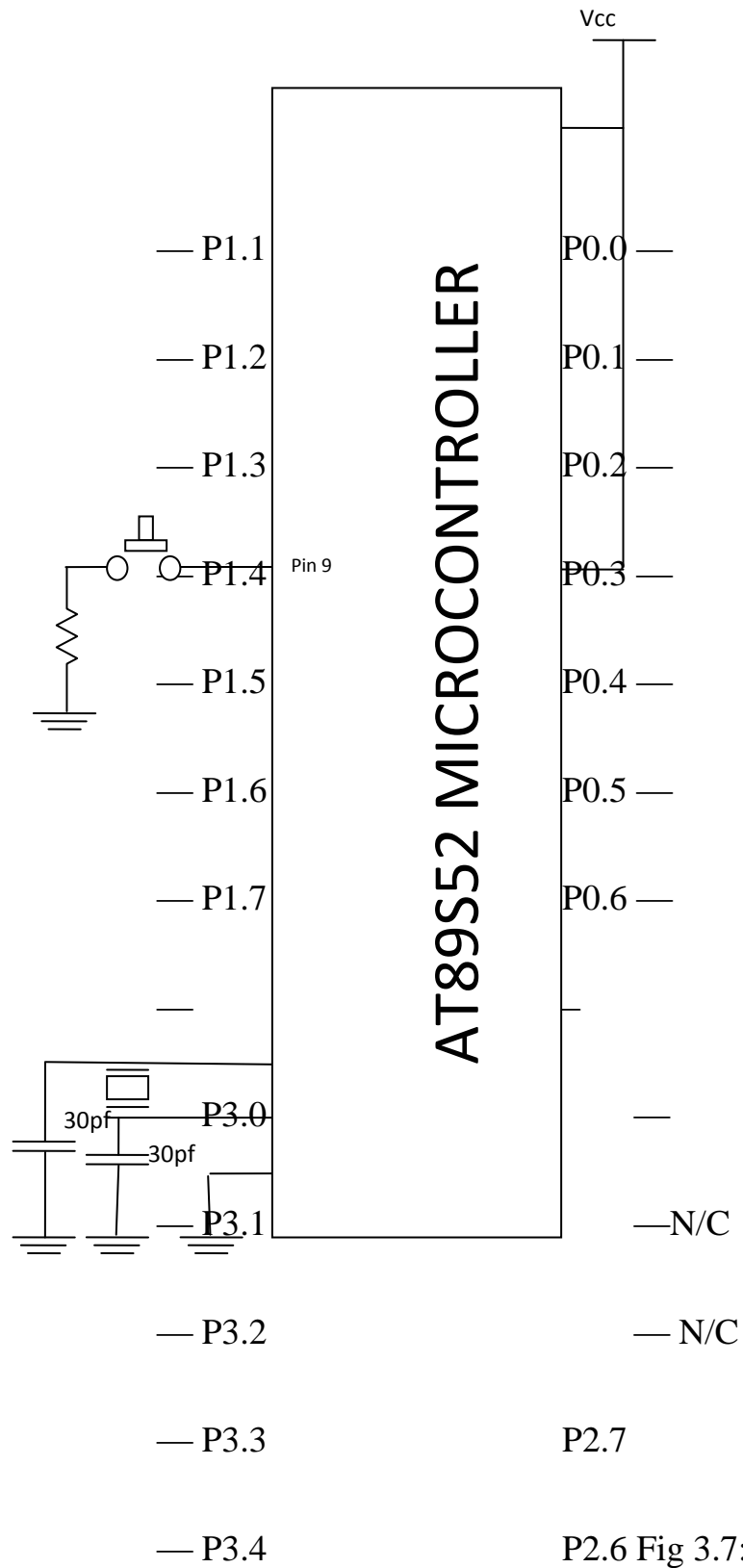

Fig 3.7: Powering the

microcontroller

### 3.6.2 CRYSTAL OSCILLATOR UNIT

This unit controls the speed of the microcontroller. It is shown in the diagram below

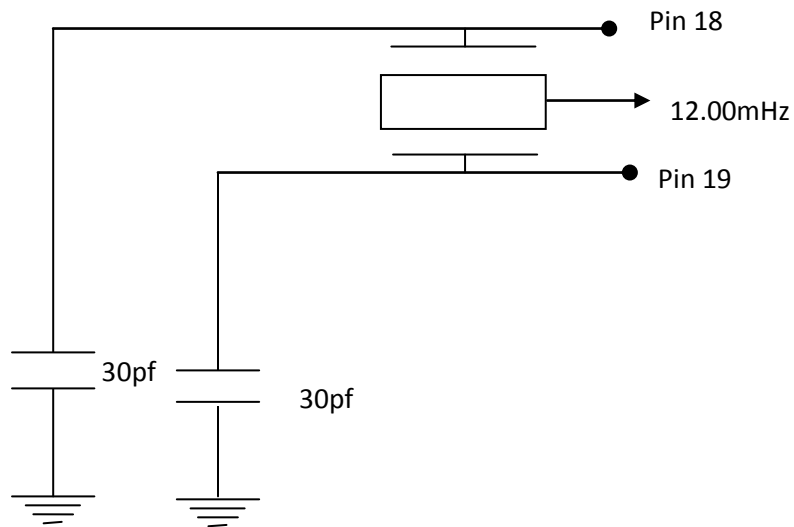

Fig. 3.8: Crystal oscillator unit

### 3.6.3 SMART CARD UNIT

The smart card unit is constructed using Vero board and PCI slot. It is constructed such that when the microcontroller receive a particular bit pattern from the card, it will give the appropriate response and display on screen “enter pin”

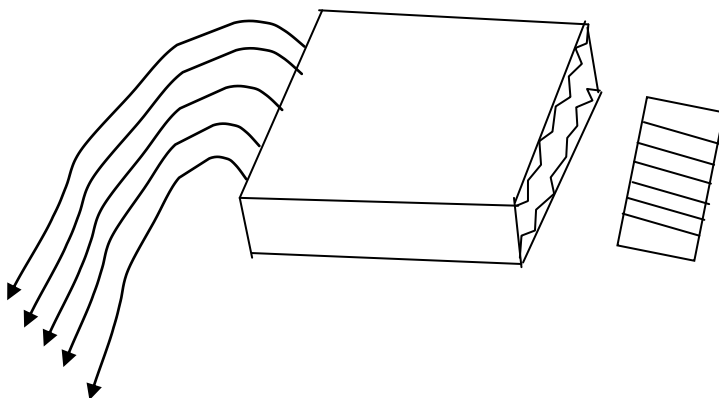

Fig 3.9: Smart card unit

### **3.8 POWER SUPPLY UNIT**

The power supply section is constructed to serve as a source of electromotive force (EMF), which provides the electrical energy to drive the current in the circuit. The supply used was a direct current. The transformer used was a step down transformer (220VAc to 12VAC). The output of the transformer is 50V, using a 300uf capacitor to remove the AC ripples impurities. Since the AC at the primary coil of the transformer is not steady hence affects the secondary coil and other voltage. The regulator used was 7805, which supplies only 5V dc current.

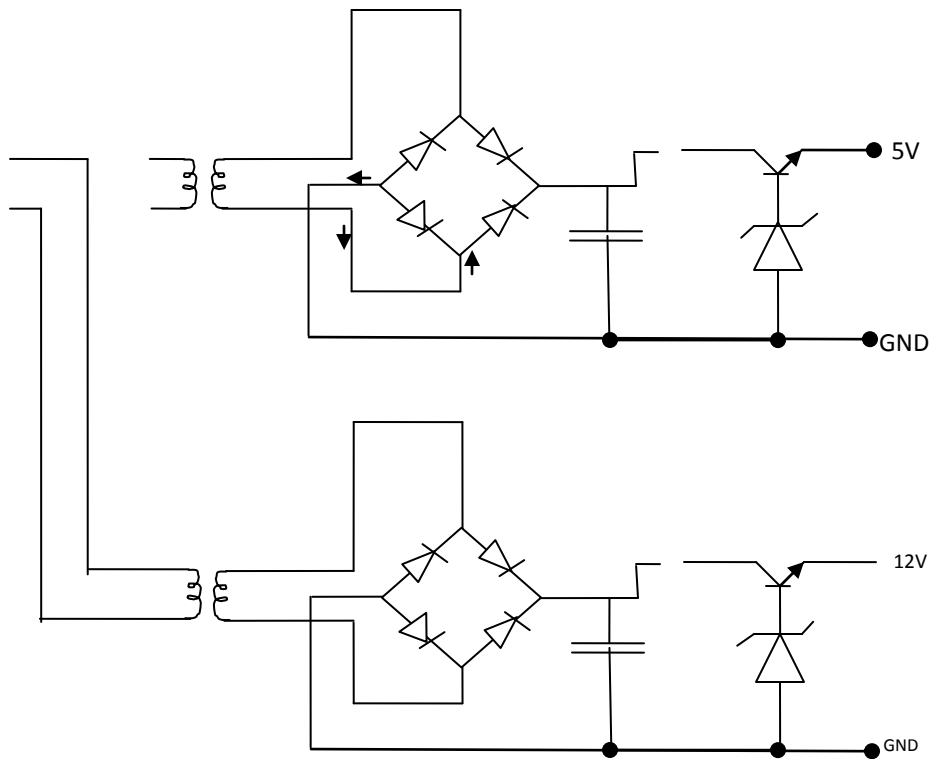

Fig. 3.10: Power Supply diagram

In the above power supply diagram, it consists of two-regulated supply; one supply 5V while the other supplies 12V. The process undergone in this supply is the same from transformation, rectification, filtration and voltage regulation.

### 3.8.1 STEPDOWN

This is a transformer that step down an AC source of 220V (mains) to 12V AC.

### 3.8.2 RECTIFICATION

It is a process that involves converting a step-down voltage of 12V Ac into Dc volts through a bridge rectifier (diode). The output of this rectifier circuit is usually a pulsating Dc voltage. This voltage is not good for electronic component like computer, radio, TV as well as this project. Hence there is need for a filter circuit to obtain a more stable voltage.

A rectifier is a Pn junction (semi-conductor) called a diode. It functions as a switch as it allows current only in one direction (forward) and acts as an open circuit when current is passed in the reverse direction. When a forward positive voltage is applied to the positive terminal of the diode, it conducts current by allowing electron flow through its Pn junction (forward biasing). But when it is reversed biased on applying negative potential to the positive terminal (reverse biasing), the diode do not conduct as it functions at this point like an open circuit.

There are two types of rectification, these are;

(a) Half wave rectification: Here it is only when the positive voltage biasing the positive terminal of the diode that there will be an output. Therefore, in half wave only the positive alternative is converted into output.

(b) Full wave rectification: In full wave rectification both the forward and reverse biasing and negative and positive alternation are converted into output.

This is achieved through two means;

i) Introduction of center tap in the secondary coil of the transformer. Due to the center tap in the secondary coil, the two coils in series created by the center tap are out of phase from each other. That at every one time, one of the diode is forward biased while the other is reversed biased. Therefore, when one conducts, the other remains as open circuit and vice versa.

ii) Use of a rectification bridge system: This is another technique of achieving a full wave rectification in power system. Here two diodes are connected in parallel then connected in series to another pair of parallel-connected diode to form the bridge. This is illustrated in the diagram below

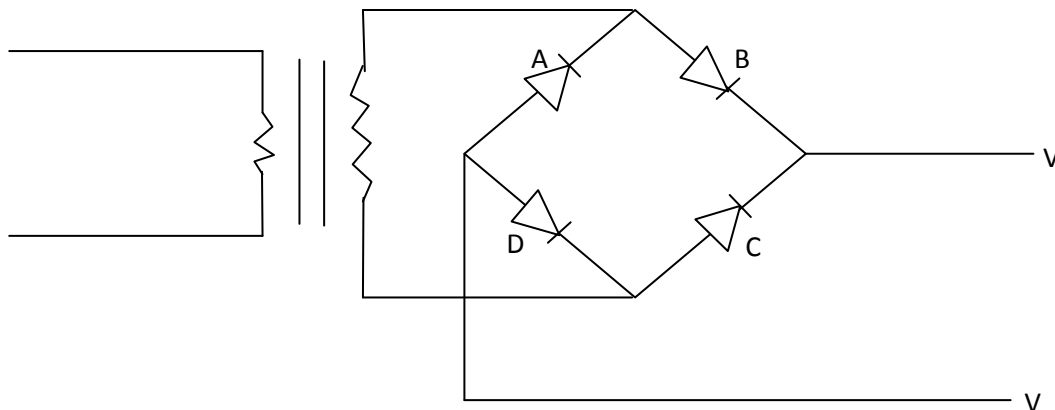

Fig. 3.11: Bridge rectifier

In the diagram, if the bridge is forward biased, rectifier B and D will conduct to give an output while on the reverse, rectifier C and A will conduct to give an

output of dc voltage. Here both negative and positive alternative gives a dc voltage output. This is possible because at any given time two parallel diode works to perform the rectification function by completing the circuit, depending on the type of biasing applied.

### 3.8.3 FILTERING

Filtering is one of the processes of signal conditioning in which high frequency signal and superimposed AC ripples on the voltage output are removed by greatly reducing the amplitude of their undulation until they are no more than a ripple.

In electronics, the pulsating dc output after transformation and rectification is not a satisfactory power source for most electronic circuit so, the filter is used to smoothen the pulsating dc voltage output so that a nearly constant dc voltage is obtained for the load. There are different types of filters they are:

i) Single capacitor filter

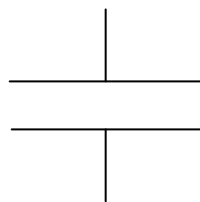

ii) Inductor filter

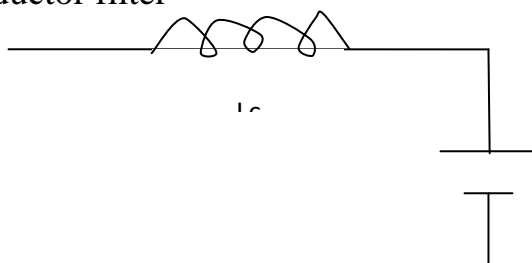

iii) Pie filter

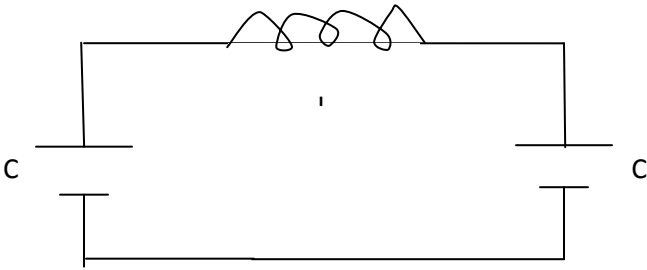

In the three mentioned types of filter, the single capacitor filter is the simplest type and it is connected in parallel to the output dc voltage from the rectifier.

In choosing a filter capacitor, one with large capacitor and whose voltage, is greater than the circuit voltage requirement is favored.

### **3.9 SYNCHRONOUS 12V DC MOTOR**

A synchronous motor is an electromagnetic device that produces a mechanical action when the rotor circuit is locked into step magnetically with the rotating magnetic field.

#### **OPERATION OF THE SYNCHRONOUS MOTOR**

When the stator windings of a synchronous motor are excited with a source of direct current a rotating magnetic field is established. However, it is synchronicited



by induction but by a source of direct current, hence the rotor is brought up to synchronous speed, with the rotor poles excited, the poles of the rotor are attracted by the poles of the rotating magnetic field and the rotor continues to turn at synchronous speed. The rotor is locked into step magnetically with the rotating magnetic field. Therefore synchronous motor develops torque only when running at synchronous speed.

### **STARTING A SYNCHRONOUS MOTOR**

A synchronous motor may be started with a small auxiliary motor mounted on the main motor shaft and it is used only during the starting period, but most are started by means of squirrel cage winding embedded in the face of the rotor poles. The motor is then started as an induction motor and is brought to about 95 percent of synchronous speed. The value of emf indeed during starting is limited by short circuiting the field winding through a resistance. Synchronous motor are excited by the use of exciter, the output of the exciter is rectified and connected directly to the motor field. There is also the field-discharge resistor and a semiconductor control circuiting which automatically switches the field – discharge resistor during starting and automatically applies the field excitation to the motor at the proper time to cause it to pull into step.

## **3.10 MECHANICAL UNIT**

### **3.10.1 FABRICATION OF COMPONENTS PARTS**

Every component in this design with the exception of those bought as standard materials (bolts and nuts, sliding contact, synchronous dc motor and all the electrical components) is fabricated and tailored to suit the desired objective of this project (design and construction of a microcontroller based security door using smartcard).

### **3.10.2 MECHANISM CASING**

The mechanism casing is 200mm x 300mm x 80mm rectangular box. It is fabricated using aluminum, it was cut using the hand shearing machine, all the edges were filed and the compartment was screwed together using bolts and nuts. The same size of a dark shaded glass was used to cover the front part of the mechanism casing; this is to allow for the viewing of the display unit which is contained inside the compartment. This casing is attached to the right side of the door post.

### **3.10.3 DOOR POST**

The door post is a 420mm x 530mm x 210 mm frame made with aluminum steel with an extension of about 380mm vertically, where the door slides on. The various parts were cut, filed and bolted together using bolts and nuts.

### **3.10.4 THE DOOR**

The door is a 300mm x 450mm dark shaded glass of thickness 0.3mm. The edges were filed and a hole was drilled on it through which it was bolted to the drive.

## **3.11 SOFTWARE DEVELOPING**

This involves a series of steps or set of activities which are necessary for the development of reliable and maintainable software. It is of great importance that hardware design cannot be used in microcontroller based system without dependable software. A typical microcontroller development system includes visual display unit (VDU), keyboard, Random Access Memory (Ram) which serves as store for the program and programmer. Software system is a term used to describe program which was provided by the manufacturer to aid the development of user (application) programs. These include program which convert assembly

language into machine codes (assembly) or high language into machine code (compiler). It also includes programs which facilitate program modification (editor). The computer aided development methodology which is essential for software development, as was used on this project are;

### **3.11.1TEXT EDITOR**

This is a word processor that is used in programming. After keying in the program codes using the input device Text editor is used to correct errors in the program. In a nutshell, the text editor is used to edit a program after it has been written.

### **3.11.2TRANSLATOR**

There are two types of translator, they are assembly and compiler. An assembly translator translates assembly language in form of mnemonic (memory aids) into machine code. A good feature of assembler is creating a list that shows the machine code and assembly language of a program side by side. A compiler on the other hand translates a high level language into machine code.

### **3.11.3 LINK / LOCATOR**

The different modules must be joined together in the correct sequence and must be bound to addresses. The link / locator pair work together to coordinate between the separate modules for smooth program execution.

### **3.11.4 LOADER**

The loader aids in loading the program in the random access memory (Ram).

### **3.11.5 TESTING**

After writing the program, it must be tested; this involves executing the program with selected input call test cases. The result of the test is used to decide whether or not a program is functioning as desired.

### **3.11.6 DEBUGGING**

This involves detecting out removable errors in a program. Different methods are involved;

i) Single stepping: In this method, debugging is done using one instruction at a time, until the entire program is debugged.

ii) Break Point: A break point is a point in a program where the execution of the program is stopped and control is transferred to another memory location for the purpose of debugging.

### **3.12 DEVELOPMENT PROCESS**

In writing the software for this project, a milder approach was employed. This made it easier to check for error and debug the program. Three major tools were used in the development process; A 51 assembler was used to translate from the source code into the object code. The L51 was employed to link the program while the OHS 51 did the conversion from binary to hex. The choice assembly language was chosen because it makes a program small and enhances faster execution. High level language is complex so we did not use it.

### **3.13 PROGRAM ENTRY AND EDITING**

After the design of the software, a text editor was used to

Enter the source code into the disk file (microcontroller).

### **3.14 ASSEMBLY AND LINKING**

After the source code of the door-controlling system has been transformed into object code for the microcontroller 89S52, the assembler 9A 51) then an object file and listing file. These two files generally represent the result of the assembly.

After assembly process, the linker (L51) processes the different object modules and binds all re-locatable modules to specific address locations in the memory. It also joins segments with the same name and type and ensures that all reference between modules are resolved. Finally it summarizes listing files which shows the comprehensive results of link/locate operation.

### **3.15 HEXADECIMAL CONVERSION**

This is achieved by the OHS 51. The OHS51 is the hex conversion code.

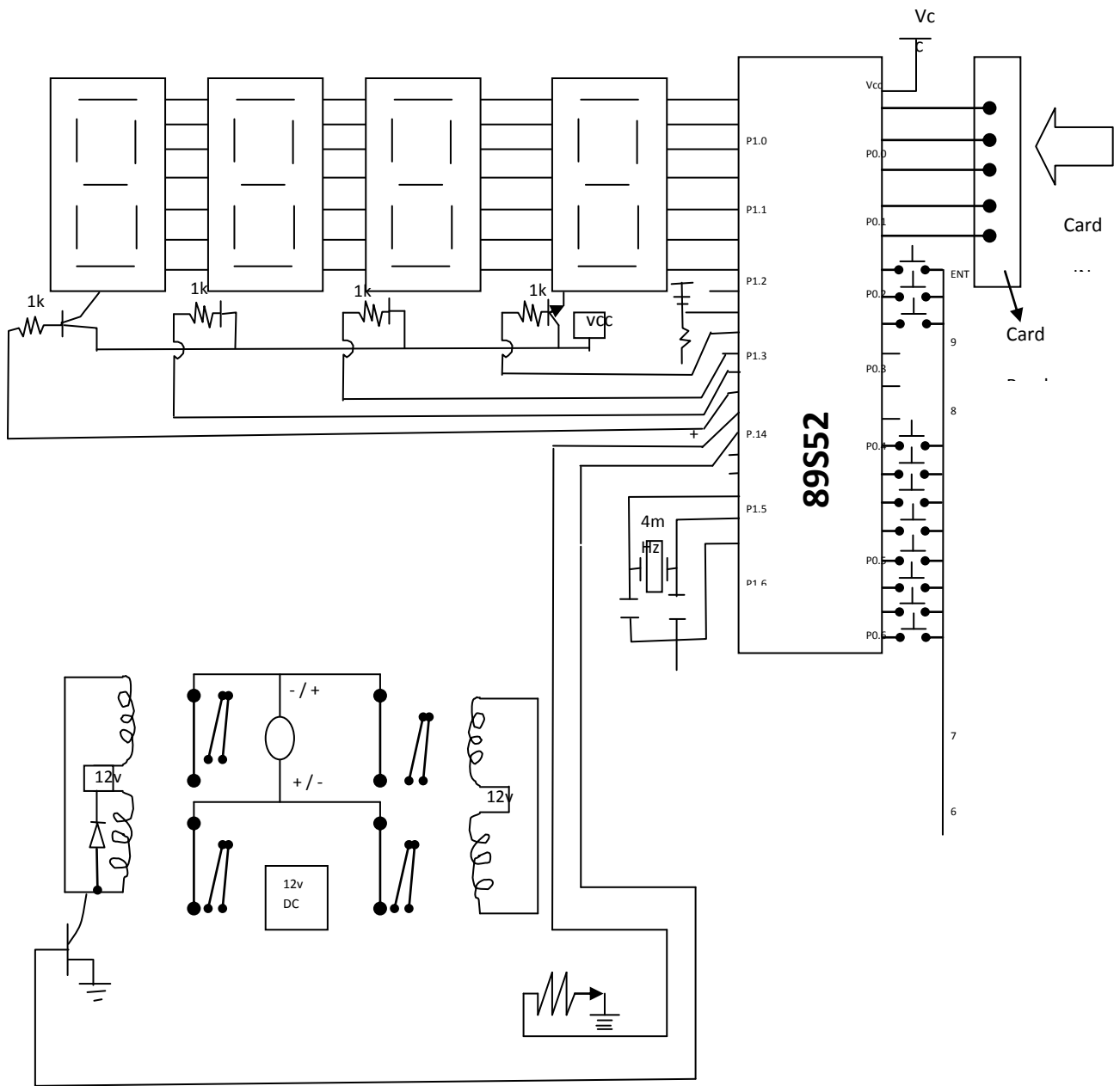

3.13 CIRCUIT DIAGRAM



## **CHAPTER FOUR**

### **4.0 MATERIAL SELECTION, ASSEMBLY PROCESS, COST ANALYSIS, TEST & RESULT,**

#### **4.1 MATERIAL SELECTION**

The knowledge of properties of material is of great importance in any engineering design. The component parts or elements of any design should be made of material that has properties that are most suitable for the conditions of operation. The selection of the proper material for any design is one of the most difficult problems of a design. The best materials are those that serve the desired objectives at minimum cost. In selecting the material we used in this project construction, we put the following three factors into consideration;

- i) Availability of the material
- ii) Suitability of the material for the working conditions in service
- iii) The cost of the material

Based on the above factors, the materials used for the various components of the design are discrete components such as resistors, diodes, capacitors, bridge rectifier, voltage regulators, microcontroller, transistors, LCD, electromechanical component such as electric motor, relay and mechanical components such as aluminum bolts and nuts, glass.

## **4.2 ASSEMBLY PROCESS**

The design work is made up with software and hardware. The software program of this design is written with assembly language program while the hardware comprised of the control unit, the input unit, the power supply unit and the display unit. Input unit have card slot where cards are inserted for access purpose and it is connected to the control unit through port zero (P0) of microcontroller. The sensor unit (keypad) is made of micro switches, which transmits information of the control unit through port two (P2) of the microcontroller especially when each of them is pressed. The display unit are made with liquid crystal display arranged serially to each other and are connected to the control unit through port one (P1). The control unit is made up of microcontroller which is the heart of the design as it accepts from the sensor unit (keypad) and the input unit through port one (P1) to the display unit. These connections are performed using soldering techniques to solder some of the components to Vero board while the necessary connections are finished with Jumper wires.

## **4.3 COST ANALYSIS**

Cost is a major factor taking into consideration not only in the selection of the material employed, but also in the processing of the selected materials. The

material selected and processes employed are such that the cost is reduced to possible minimum. The cost of component employed in the fabrication is shown in

Table 3.1

s/n	Component description	Unit Cost	Quantity	Total cost
1	Transformer	900.00	2	1800.00
2	Capacitor	10.00	10	100.00
3	Relay	20.00	4	80.00
4	Regular	40.00	2	80.00
5	Microcontroller	1900.00	1	1900.00
6	DC motor 12v	3500.00	1	3500.00
7	Vero board	200.00	1	200.00
8	Keypad	40.00	10	400.00
9	Resistors	10.00	10	100.00
10	Transistor	10.00	8	80.00

11	Micro switch	20.00	1	20.00
12	Rectifier	50.00	2	100.00
13	Door Frame work	8000.00		4000.00
14	Expansion slot	300.00	1	300.00
15	Transport	2500.00		2500.00
16	Liquid crystal display	3000	1	3000.00
				25,320.00

#### **4.4 TESTS AND RESULT**

Several tests were carried out on the device to confirm the level of its performance and efficiency. In the power unit, test was conducted using the digital multimeter to read the output voltage of the power supply. We confirmed that the terminal output read the appropriate value. From the sensor unit, confirmations were made so that the micro switches used could deliver right information when the button is pressed. From the control unit, serious testing was conducted to ensure that output is given in accordance to the input. This testing is the most important of the design because of its link to other units in the design. The input section was tested using multimeter and logic probe to ensure that no mistake was made in data transfer. After all these testing, we were convinced that the design work was successful in respect of software development and hardware assembly.

## **CHAPTER FIVE**

### **5.0 DISCUSSION OF RESULTLS**

This research work was very interesting and has broadened our knowledge mostly in the field of assembly language programming and hardware design. Though this work was successful, many unexpected problems were encountered along the line of design. Some components were expensive and difficult to get, while some not readily available in the market like smart card. Practical experience was not much before embarking on the project, but this lead us to make depth research from internet services using so many search engines to find how to device means towards providing smartcard for the design. We also consulted some material textbooks from the school library and from reference sections. We tried to seek advice from experts in the field of designing and programming to enable us carry out the project successfully.

### **5.1 CONCLUSION**

This project was the construction of a microcontroller based security door using smartcard. The main purpose and objective of the project has been achieved, since

the smartcard was able to transmit information to the control unit, the controller accepts the information transferred and process them by prompting for password (Enter pass-ward) when the code has been entered through the input with the help of keypad, the controller is found to be able to interpret the information and process it again without problems. It however displays “ACCESS GRANTED” or “ACCESS DENIED” depending on the information it has been fed with. This project has also satisfied the objectives by becoming interactive since it can ask question! e.g. insert smart card. After the card insertion, another question goes requesting for the users pass-word. It checks the password and decides if the door/gate will be open or remain closed. It is human friendly and can be used by any person who is authorized. This project was proved beyond reasonable doubt that with programming imaginations can be made real.

## **5.2 RECOMMEDATION**

In future, pin-code and thumbprint should be used in the construction of microcontroller based security door instead of smartcard because card can easily be forged. Webcam should be also be used in case there is a problem it will be used to identify the offender.

## REFERENCES

Dedoo G.j and Burro C.N (1971), *Integrated Circuit and Semi-conductor Device Theorem and Application* New York.

Ejimofofor C.O (2011), *Promixity Switches Caritas University Enugu*

Edward Hugas (1997) *Electrical Technology*, Addison-Wesley Publisher, 7<sup>th</sup> edition.

Hozowhz, P, Kenifiel, H (1995) *The Art of Electronics Cambridge University Press*, London.

Kelvin R. Sullivan. 91992). *Mostfet Device, Physics and Operation IEEE Tran.* New York Mac Grew-Hill.

S. Chad and Company, New Delhi.

Slouch Mtsumoto. (2000), *Understanding and Using DC and AC Inverters jay Car-Electronic* New York.

Theraja B.I (2000), *Text Book of Electrical Technology*

S. Chand & Company, Ram Nagar, New Delhi.